

ROD CLAMP BREAKER

UM-036-400SS

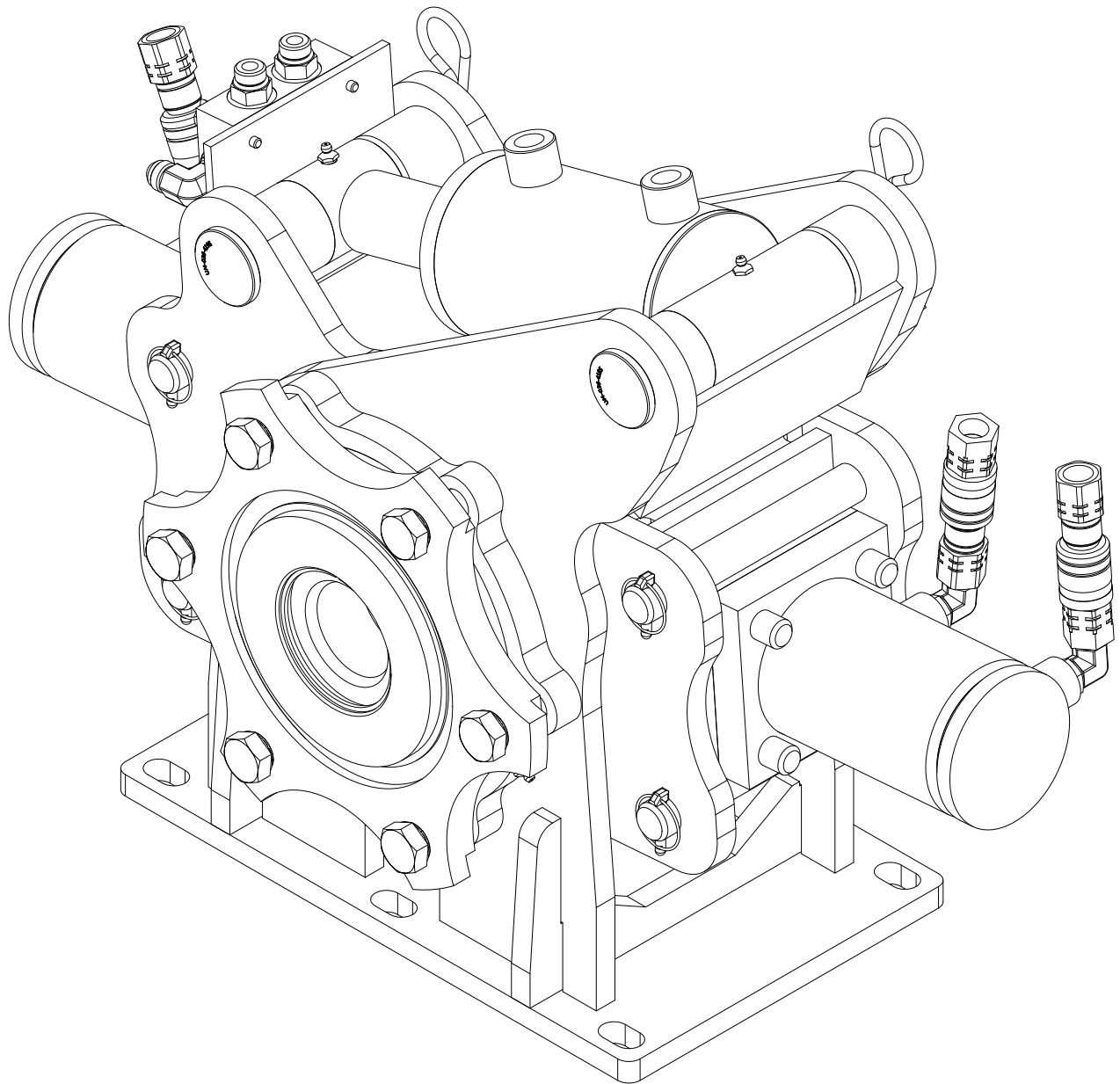

180 Des Distributeurs
VAL D'OR, Québec
CANADA J9P 6Y1
TEL: 819-824-3977
FAX: 819-824-1077

USINAGE
MARCOTTE Inc.

CE PLAN EST SUSCEPTIBLE D'ÊTRE MODIFIÉ SANS PRÉAVIS. VEUILLEZ CONTACTER UN RESPONSABLE DE L'ÉQUIPE TECHNIQUE D'USINAGE MARCOTTE POUR OBTENIR UNE VERSION PLUS RÉCENTE SI NÉCESSAIRE.

THIS DRAWING CAN BE MODIFIED WITHOUT NOTICE. IF NECESSARY, CONTACT USINAGE MARCOTTE'S TECHNICAL TEAM TO GET AN UPDATED VERSION.

ESTE PLAN PUEDES CAMBIAR EN CUALQUIER MOMENTO. CONTACTO USINAGE MARCOTTE PARA INFORMACION.

DATE: 2015-10-20

REV

PAGE 12-1

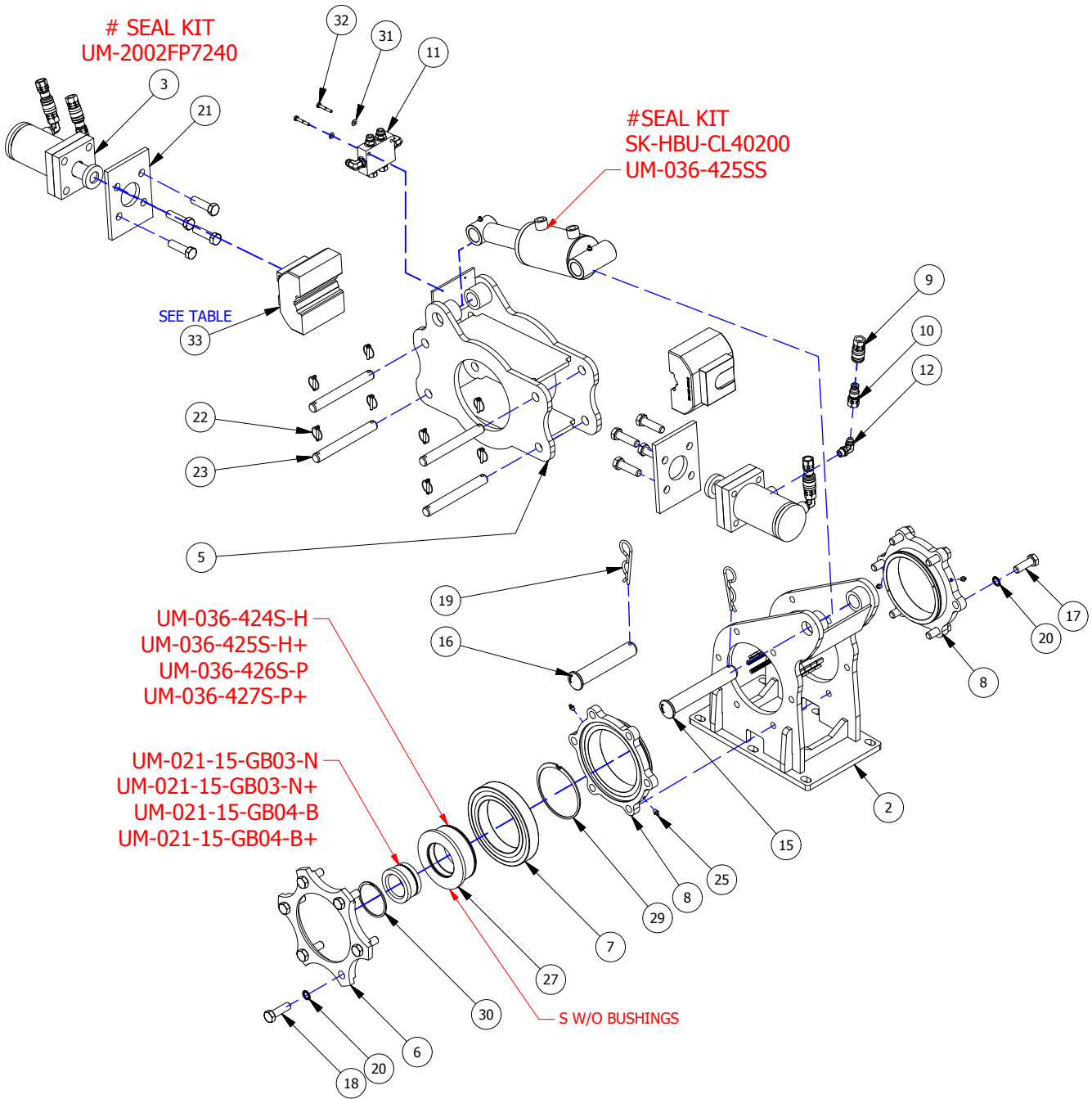

UM-036-424S-H
 UM-036-425S-H+
 UM-036-426S-P
 UM-036-427S-P+

UM-021-15-GB03-N
 UM-021-15-GB03-N+
 UM-021-15-GB04-B
 UM-021-15-GB04-B+

S W/O BUSHINGS

TABLE

JAW NO.	SIZE
UM-036-450B	B
UM-036-451N	N
UM-036-452H	H
UM-036-453P	P

DRAWN BY: JOEL AUBE

COMPLETE ASSEMBLY NO.: UM-036-400SS

ROD CLAMP BREACKER

UM
 180 Des Distributeurs
 VAL D'OR, Québec
 CANADA J9P 6Y1
 TEL: 819-824-3977
 FAX: 819-824-1077

USINAGE
MARCOTTE Inc.

CE PLAN EST SUSCEPTIBLE D'ÊTRE MODIFIÉ SANS PRÉAVIS. VEUILLEZ CONTACTER UN RESPONSABLE DE L'ÉQUIPE TECHNIQUE D'USINAGE MARCOTTE POUR OBTENIR UNE VERSION PLUS RÉCENTE SI NÉCESSAIRE.
 THIS DRAWING CAN BE MODIFIED WITHOUT NOTICE. IF NECESSARY, CONTACT USINAGE MARCOTTE'S TECHNICAL TEAM TO GET AN UPDATED VERSION.
 ESTE PLAN PUEDES CAMBIAR EN CUALQUIER MOMENTO. CONTACTO USINAGE MARCOTTE PARA INFORMACION.

DATE: 2015-10-20 REV 0 PAGE 12-2

LISTE DE PIÈCES / PARTS LIST - LDP

ITEM	ORDER #	DESCRIPTION - FRANÇAIS	DESCRIPTION - ENGLISH	QTY
2	UM-036-410SS	BASE DE FOOT CLAM UM ASSEMBLÉ	ASSEMBLY BASE FOOT CLAM UM	1
3	UM-036-103BB	CYLINDRE ASSEMBLÉ	CYLINDER ASSEMBLY	2
5	UM-036-415SS	SECTION FOOT CLAM UM ASSEMBLÉ	SECTION FOOT CLAM UM ASSEMBLY	1
6	UM-036-347B	BEARING HOLDER	BEARING HOLDER	1
7	6030_2RS	BALL BEARING	BALL BEARING	1
8	UM-036-412S	BEARING HOLDER	BEARING HOLDER	2
9	HTMC-06-08	FLAT FACE FEMALE QUICK COUPLING 3/8-1/2 NPT	FLAT FACE FEMALE QUICK COUPLING 3/8-1/2 NPT	4
10	HTMN-06-08	FLAT FACE MALE QUICK COUPLING 3/8-1/2 NPT	FLAT FACE MALE QUICK COUPLING 3/8-1/2 NPT	4
11	UM-036-126BB	VALVE DE CONTROLE	VALVE CONTROL	1
12	6801-8-8	MJIC 8 x MORB 8 - 90 DEG	MJIC 8 x MORB 8 - 90 DEG	4
15	UM-036-418S	PINE	PINE	1
16	UM-036-419S	PINE	PINE	1
17	B750-2250	BOLT 3/4-UNC X 2 1/4"	BOLT 3/4-UNC X 2 1/4"	6
18	B750-2500	HEX BOLT 5/8-11 UNC X 1 3/4	HEX BOLT 5/8-11 UNC X 1 3/4	6
19	HP1500	HAIR PIN 1 1/2 in	HAIR PIN 1 1/2 in	3
20	677-107	NORD-LOCK	NORD-LOCK	12
21	UM-036-420S	PLAQUE POUR CYLINDRE	CYLINDER PLAT	2
22	LYP-250-1500	LYNCH PIN 1/4 x 1 1/2	LYNCH PIN 1/4 x 1 1/2	8
23	UM-036-411S	PINE	PINE	4
25	1/8 NPT ST Zerk	1/8 NPT ST Zerk	1/8 NPT ST Zerk	4
27	UM-036-423S	ADAPTEUR GUIDE TIGE	ADAPTOR GUIDE RODE	1
29	R3100-600	RETAINER RING	RETAINER RING	1
30	R3000-X354ZP	RETAINER RING	RETAINER RING	1
31	W250	WASHER 1/4 STD	WASHER 1/4 STD	2
32	B250-1750Z	HEX BOLT 1/4-20 UNC - 1,75 ZINC PLATED	HEX BOLT 1/4-20 UNC - 1,75 ZINC PLATED	2
33	UM-036-450B	JAW B	JAW B	2



CE PLAN EST SUSCEPTIBLE D'ÊTRE MODIFIÉ SANS PRÉAVIS. VEUILLEZ CONTACTER UN RESPONSABLE DE L'ÉQUIPE TECHNIQUE D'USINAGE MARCOTTE POUR OBTENIR UNE VERSION PLUS RÉCENTE SI NÉCESSAIRE.

THIS DRAWING CAN BE MODIFIED WITHOUT NOTICE. IF NECESSARY, CONTACT USINAGE MARCOTTE'S TECHNICAL TEAM TO GET AN UPDATED VERSION.

ESTE PLAN PUEDES CAMBIAR EN CUALQUIER MOMENTO. CONTACTO USINAGE MARCOTTE PARA INFORMACION.

DATE: 2015-10-20

REV 0

PAGE 12-3

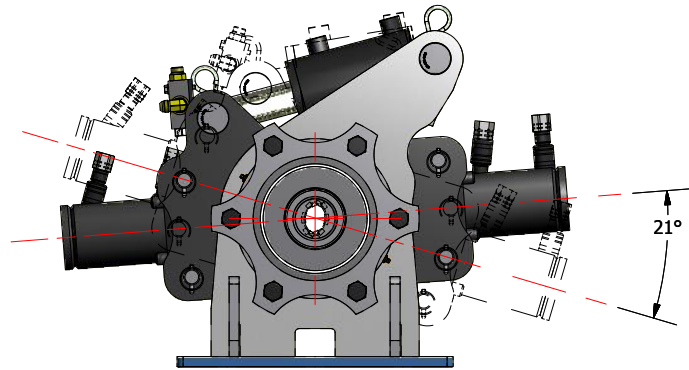
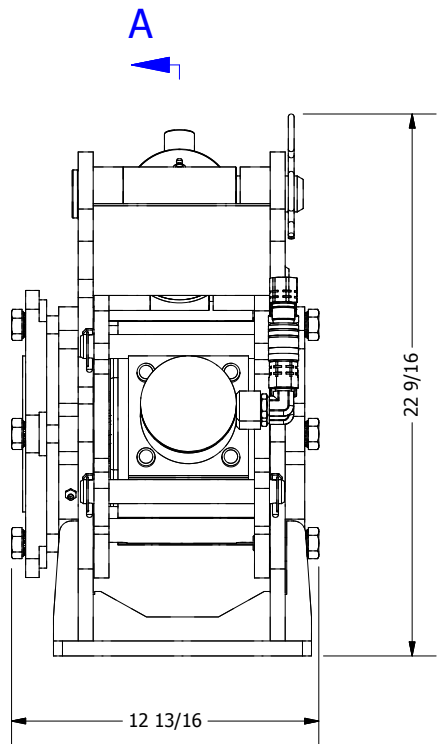

POID TOTAL: 436lbs/157kg

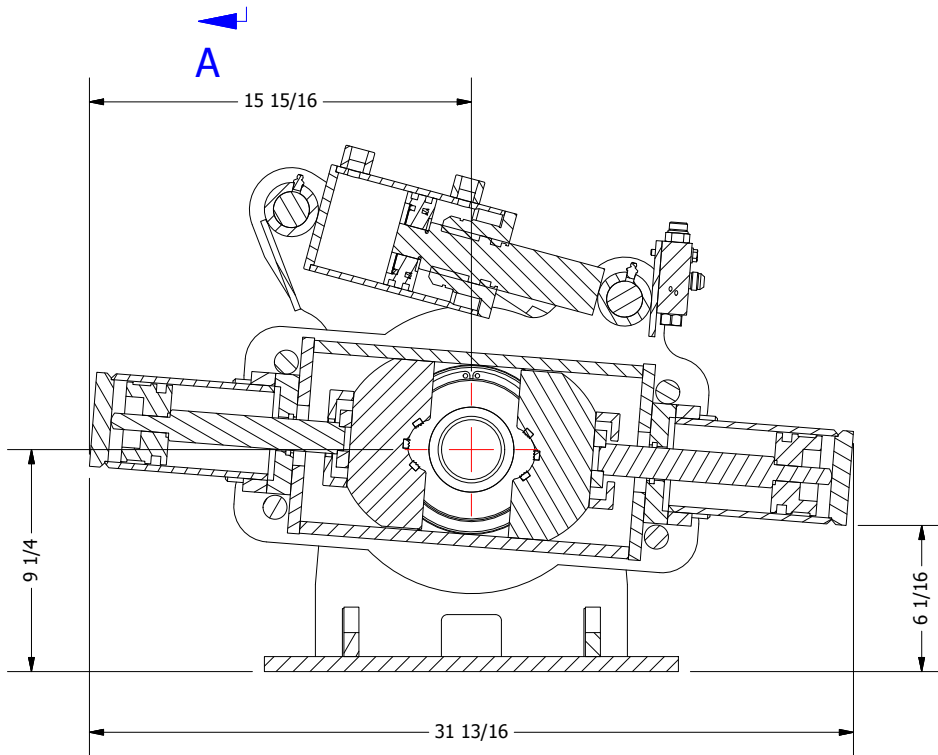

**SECTION A-A
OUVERT**

DRAWN BY: JOEL AUBE

COMPLETE ASSEMBLY NO.: UM-036-400SS

ROD CLAMP BREAKER



180 Des Distributeurs
VAL D'OR, Québec
CANADA J9P 6Y1
TEL: 819-824-3977
FAX: 819-824-1077

USINAGE
MARCOTTE Inc.

CE PLAN EST SUSCEPTIBLE D'ÊTRE MODIFIÉ SANS PRÉAVIS. VEUILLEZ CONTACTER UN RESPONSABLE DE L'ÉQUIPE TECHNIQUE D'USINAGE MARCOTTE POUR OBTENIR UNE VERSION PLUS RÉCENTE SI NÉCESSAIRE.

THIS DRAWING CAN BE MODIFIED WITHOUT NOTICE. IF NECESSARY, CONTACT USINAGE MARCOTTE'S TECHNICAL TEAM TO GET AN UPDATED VERSION.

ESTE PLAN PUEDES CAMBIAR EN CUALQUIER MOMENTO. CONTACTO USINAGE MARCOTTE PARA INFORMACION.

DATE: 2015-10-20

REV 0

PAGE 12-4